



***Owner's Operating Manual
& Safety Information***

INFLATABLE SPORT BOATS

Dolphin 8.8'
Air Floor

White Marlin 9.8'
Air Floor

Swordfish 10.8'
Air Floor

Manta Ray 8.8'

Shark 9.8'

Killer Whale 10.8'

On Point Products

116 Talgarth Ct., Roseville, CA 95661

www.inflatableportboats.com | (530) 268-4757

Contents

- 3** Operation and Safety
- 4** Watersports Industry Association
Responsibility Code
- 5** Product Details
- 6** Packing List and Assembly
- 8** Inflation
- 9** Disassembly
- 10** Operating Information (Loading, Towing,
Rowing, Outboard Motor)
- 12** Repairs and Patching
- 13** Environmental Protection, EC Declaration of Conformity
- 14** Warranty Information
- 15** Manufacturer's Certificate of Origin for Registration
- 16** Available Boat Accessories and Attachments

HIN #: ASTSB#####

(HIN # will be located on the CE Plate on your Sport Boat transom)

Congratulations! You are now the proud owner of an Inflatable Sport Boat. Inflatable Sport Boats are manufactured to provide a premium inflatable boat with the highest quality material, hand crafted design, durability, and performance to last. These boats are built with a heavy duty UV and puncture resistant PVC material that is welded together to guarantee long lasting exceptional performance for years. Constructed to succeed in providing you a multi-sport, all environment, and inflatable tender.

Each boat has an identification number, which you will find on the CE plate under HIN #. The first letter and figures of this ID number have already been printed on the Manufacture Certification of Origin document at the back of this manual. Please complete it by taking down the missing figures/letters. This ID number is to be mentioned in every correspondence with us or any authorized service station. The HIN # is customized for each individual inflatable sport boat made. It is only with this number that we will be able to identify your boat and give you the relevant information.

Operation and Safety Information



WARNING

BEWARE OF OFFSHORE WINDS AND CURRENTS!

It is the responsibility of the boat's operator to know all laws applicable to boats and to comply with those laws when equipping and operating the boat.

Rules and regulations may vary depending on the following conditions: the location of the boat's operation and the requirements of local authorities; the use of the boat, the particular time of the day during which the boat is being used, the conditions under which the boat is being operated, and the size, speed, course, kind of boat (power, oars, etc.) and mode of operation.

In addition to knowing and following the applicable laws, please note the following:

1. Each passenger should wear the appropriate clothing and wear an approved life jacket.
2. Ensure that all basic equipment is on board the boat, including paddles /oars and an inflation pump. Be aware of the possible necessity of additional safety equipment.
3. A boat should not be operated by an individual under the influence of drugs or alcohol.
4. Weight must be distributed evenly. If your motor-equipped boat is lightly loaded, do not accelerate suddenly. Stability and handling problems can occur if the operator mishandles the craft.
5. The carrying capacity and the engine capacity and maximum weight must not be exceeded.
6. Outboard motors are dangerous and can cause injury and death when improperly operated. Never equip or operate your boat with a motor which is not approved for use with the boat. Never approach at speed a swimmer in the water or allow a swimmer to approach the stern of the boat while the engine is running.
7. Due attention should be given to winds and tides, which can change and therefore affect fuel consumption.
8. When boating in unknown waters, it is always a wise precaution to obtain local knowledge before setting out.
9. Always tell someone your time and place of departure, your proposed route and the time you expect to return.
10. The display of navigation lights may be required. The user should ensure that the boat should not be operated during darkness or other hazardous weather conditions unless a correct navigational lighting has been fitted and is operating properly.
11. Safety courses on boat handling are available in most countries from national or local organizations. Operators should acquaint themselves with the general rules of the waterways and the local water conditions before taking a boat out.
12. On extended voyages, due consideration must be given to safety equipment such as flares, first aid kit, anchors, etc.
13. Make sure all passengers remain seated at all times during operation.

On Point Products
Roseville, CA 95661 | (530) 268-4757

IMPORTANT!!

**PLEASE READ THIS INSTRUCTION MANUAL THOROUGHLY
BEFORE ASSEMBLING OR USING PRODUCT. FAILURE TO
ABIDE BY INSTRUCTIONS AND WARNINGS CAN CAUSE A MISUSE
OF THE PRODUCT AND POTENTIAL INJURY HAZARD**

WATERSPORTS INDUSTRY ASSOCIATION RESPONSIBILITY CODE

Be aware that there are risks in boating and Watersports that good judgment and personal awareness can help reduce. To increase your enjoyment of boating and watersports, review these elements of the Code.

IN WATERSPORTS IT IS YOUR RESPONSIBILITY TO:

- ALWAYS familiarize yourself with applicable laws, waterways, and inherent risks.
- ALWAYS wear a properly fitted life jacket approved by your country's agency.
- ALWAYS read user's manual and inspect equipment before use.
- ALWAYS ride under control, at proper speeds, and within your limits.
- ALWAYS turn ignition off when anyone is near watercraft power drive unit.
- ALWAYS stay clear of engine exhaust to avoid Carbon Monoxide poisoning.
- NEVER ski or ride near swimmers, shallow water, other boats, or obstacles.
- BE AWARE and keep clear of swimmers and divers. Be aware of beaches and launch sites where people are most likely in the water. Shut off motor whenever in doubt of operating near someone or something in the water.
- NEVER operate watercraft, ski, or ride under the influence of alcohol or drugs.
- THE CAPTAIN of the boat is responsible to make sure all passengers have read the warnings and abide by rules.
- ALWAYS stay seated and never stand in the boat while moving.
- MAKE SURE the boat is completely inflated before operating.
- NO BOW RIDING. Bow riding is illegal in most areas and is extremely dangerous.
- KEEP ARMS AND LEGS INSIDE the boat at all time during use.

Safety, Rules, and Regulations

Rules and regulations can change depending on many different circumstances. The place or time of boat operation, the different requirements of local authorities on water rules, boat lights, speed restrictions, and many other boating rules that should be understood before operating the boat.

- In most countries, safety and boating education is available (sometimes mandatory). Captains are responsible to know the general rules and requirements prior to operation.
- Sport Boats **DO NOT** come equipped with a light for driving in the dark.
- Always check the weather before operation. DO NOT use boat during winds or offshore currents.

Product Details

Inflatable Sport Boats offer a multitude of different sizes and types of inflatable dinghy boats. Please make sure to identify which Sport Boats model you have before reading these instructions.

MODELS	LENGTH	WIDTH	CHAMBERS	MAX HP	MAX LOAD	MAX PERSONS
MANTA RAY	8'8"	5'	3 + 1	10 HP	1,070 lbs	4
DOLPHIN AIR FLOOR	8'8"	5'	3 + 1 + 1	10 HP	1,070 lbs	4
SHARK	9'8"	5'	3 + 1	15 HP	1,158 lbs	5
WHITE MARLIN AIR FLOOR	9'8"	5'	3 + 1 + 1	15 HP	1,158 lbs	5
KILLER WHALE	10'8"	5' 3"	3 + 1	15 HP	1,268 lbs	5
SWORDFISH AIR FLOOR	10'8"	5' 3"	3 + 1 + 1	15 HP	1,268 lbs	5

Packing List

AIR FLOOR BOATS

Dolphin 8.8' | White Marlin 9.8' | Swordfish 10.8'

- Inflatable Sport Boat with Air deck floor
 - 1 Aluminum slide on bench seat
- 1 Removable seat cushion and hanging bag
 - 2 Aluminum oars with lock-in holders
 - Heavy duty boat carry & storage bag
 - Foot pump
 - PVC repair patch
 - Owner's manual

(Registration paper work on back page)

ALUMINUM FLOOR BOATS

Manta Ray 8.8' | Shark 9.8' | Killer Whale 10.8'

- Inflatable Sport Boat
 - 4 or 5 Aluminum floor boards
(SB-330 has 5 pieces)
 - 4 Aluminum floor side rails
 - 1 Aluminum slide on bench seat
- 1 Removable seat cushion and hanging bag
 - 2 Aluminum oars with lock-in holders
 - Heavy duty boat carry & storage bag
 - Foot pump
 - PVC repair patch
 - Owner's manual

(Registration paper work on back page)

Assembly

Inflatable Sport Boats are manufactured to make it easy for consumers to set up and take down quick and easy. Make sure your product box came with everything listed in the packing list.

ATTENTION! Never use a compressed air source, such as an air compressor. Compressed air can cause over-inflation and potentially damage the product by rupturing seams and bulkhead.

*Maximum PSI: Boat tubes - Maximum 3.6 PSI
Keel tube - Maximum 4.5 PSI
Inflatable Air Floor - Maximum 8 PSI*

Step #1. Lay your Inflatable Sport Boat out on a clean flat surface with no sharp objects. Inflate main 3 side tube chambers about 30-50%. Just enough so the boat starts to take shape. At any time during the assembly let some air out of the tubes to make inserting the floor pieces easier.

Step #1a. AIR FLOOR MODEL BOATS: skip Steps #2-5. Inflate air floor completely (Maximum 8 PSI) BEFORE inflating the keel.

Step #2. Insert front floorboard #1 and rear transom floorboard #4. Front floorboard #1 will have a hole in it for the inflatable keel valve. Rear transom floorboard #4 (#5 for SB-330) will be the largest floorboard with a small semicircle cut out to fit around the drain valve on the transom.

Step #3. Insert middle floorboards #2 and #3 one at a time. Remember it is OK to let more air out of the boat tubes to make this process easier.

Step #4. Make "V" shape with middle floorboards so they connect. Softly push down so they snap into place and flatten.

Step #5. Add 2 side rails per side (4 total) to even out and secure all floorboard pieces. The slit on side rails will fit into the floorboards with a smooth curve side to contour and face the tube. The floor should be flattened out after this step and you are ready to fully inflate.

Step #6. Inflate all 3 boat tube chambers first and 1 keel chamber about 95% and top off the remaining 5% with the foot pump. Use a foot pump to inflate until the boat tube is rock hard and the foot pump is hard to use. Once tubes are completely inflated, floorboards should not be able to move at all. If they do move, you need to inflate your boat more.

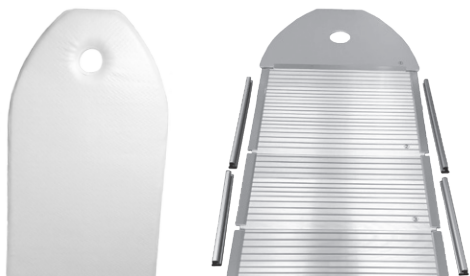

Using your smart phone's camera, TAP open the browser link that appears. This will take you to the assembly instructions webpage.



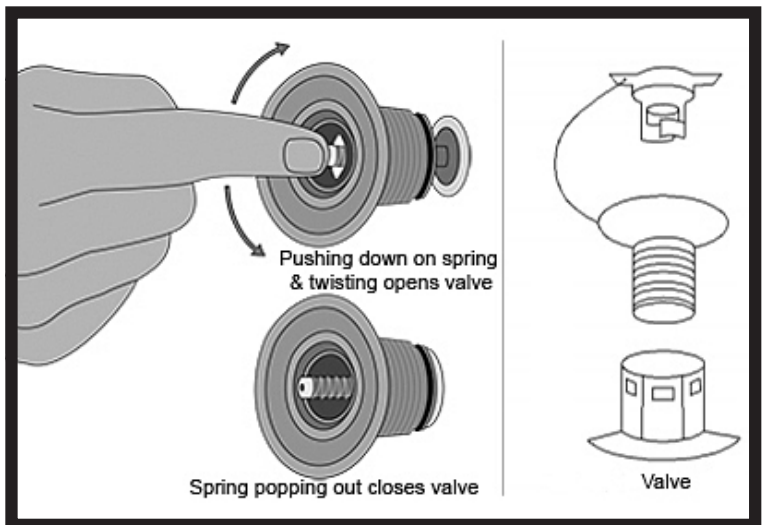
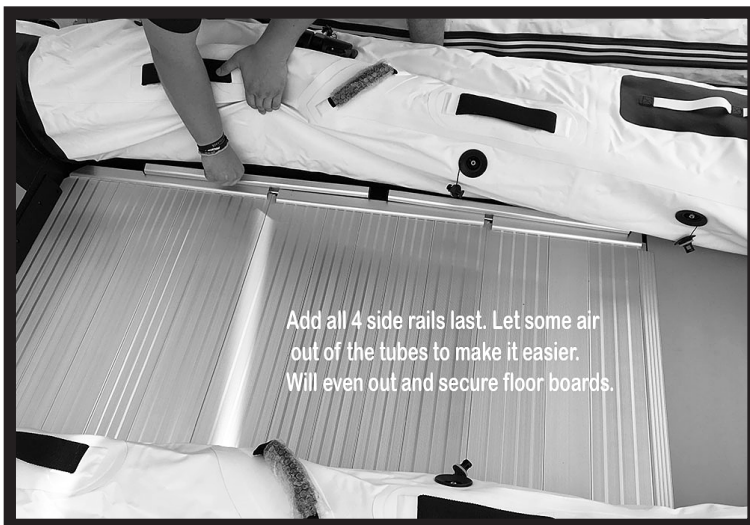
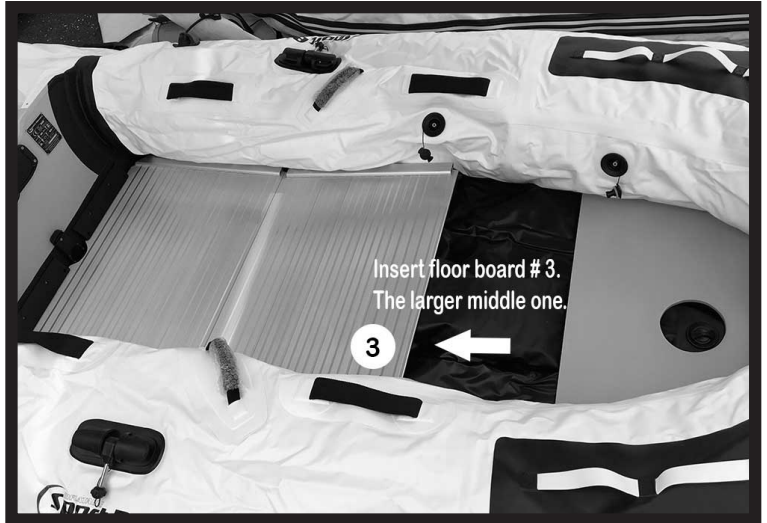
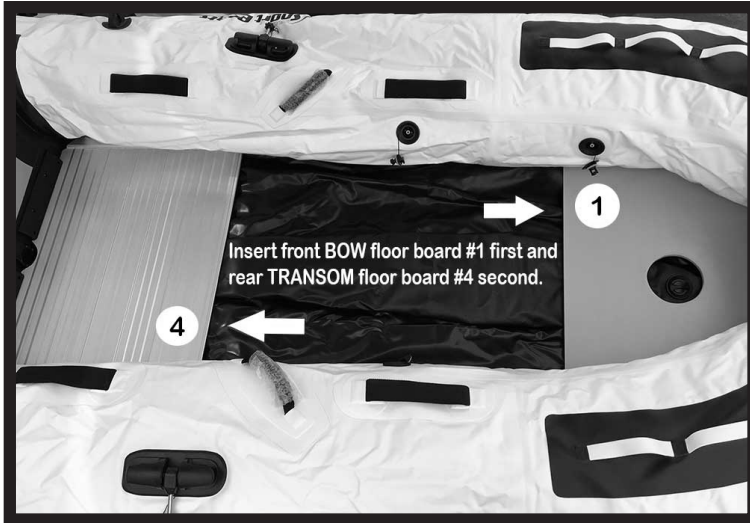

Inflation

Inflation takes approximately 8-12 minutes to completely fill the boat. Each size boat has a “Maximum PSI” clearly stated on the CE plate mounted on the boat.

Never exceeded the maximum PSI.

To Inflate:

1. Use the foot pump provided in the product box. The foot pump has a valve adaptor on it and is adequate to inflate all Sport Boats 100%. Attach the foot pump while the valve needle is popped up and closed and use to top off all tubes. This way when you remove the foot pump the valve will automatically close and air pressure will remain. You can not over inflate the product by using the foot pump.
2. You can also use any electric boat tube inflator. If the electric inflator doesn't have a PSI meter, inflate the boat 80% and then use the foot pump to achieve proper PSI pressure.
3. Maximum PSI can change for each boat. Boat pressure can fluctuate with climate change and must be monitored by boat owner before every use.
 - a. It is a good rule to check air pressure before every use.
4. Higher altitudes could change the air pressure. If the boat is inflated when at sea level and is moved to a higher altitude, while being inflated, the air pressure must be reduced to prevent over inflation.
5. PSI guide:
 - a. Boat tube - Maximum 3.6 PSI
 - b. Keel - Maximum 4.5 PSI
 - c. Inflatable “Air Floor” - Maximum 8 PSI
6. If you plan on leaving your Sport Boat inflated for a 2-3 day period, it may lose pressure and require re-inflation before use. This is common due to climate change.



Using your smart phone's camera, TAP open the browser link that appears.
Watch our video tutorial available on our website and YouTube.
<https://inflatableportboats.com/informational-videos/>

Step by step Disassembly and Storage

1. Follow step #1 in assembly.
2. Wipe down product completely before deflating. It is easier to clean while inflated.
IMPORTANT: storing a wet product can cause mildew, mold, and can damage the product.
3. After deflating the boat tubes, lift and remove one of the middle floorboards first. Remove bow and transom boards last. Place floorboards, side joiners, and oars in carry bag.
4. Use an inflator on “sucking function” to remove excess air from each chamber.
5. Fold each side of the boat into the middle. Start from the transom and roll up like sleeping bag towards the bow and place in bag.



Cleaning your Boat

Sport Boats are manufactured with a heavy duty 1100 denier weather resistant UV protected PVC material. The PVC material doesn't require any special type of cleaning agent. We recommend rinsing your boat out with general dish soap before disassembly. Let the boat dry 100% before placing in a **dry storage place**.

IMPORTANT:

- Storing a wet product can cause mildew, mold, and can damage the product. Store in a dry, covered, cool area. Storing in damp or humid areas can cause glued areas to separate. Avoid areas that have mice or rodents.
- DO NOT USE PRODUCTS CONTAINING PETROLEUM DISTILLATES. (i.e. Armorall).

Using your smart phone's camera, TAP open the browser link that appears.
Watch our video tutorial available on our website and YouTube.
<https://inflatableboats.com/informational-videos/>



Operating Information

CAPTAIN'S READ!

It is the responsibility of the captain/driver of the boat to know all the laws applicable to boats and to follow those laws when operating the watercraft. The captain of the boat is fully responsible for all passengers and making sure the passengers have read and understood all rules and warnings that apply while occupying the watercraft.

Loading

Do not exceed maximum capacity stated on each boat CE plate.

- Each person in the boat should wear a life jacket (PFD – personal flotation device)
- Oars or paddles and repair kit should be carried on board for emergencies.
- All loads should be distributed evenly for proper boat trim.

Rowing

1. Inflatable boats are equipped with oars and thole-pins.
2. Install oars in thole-pins; attach thole-pin cap screws.
Note: Do not use oars as levers, they could break!
3. Local water conditions must be taken into account before operating the boat with oars or a small outboard motor. Boat power may not be strong enough to overcome currents in tidal inlets, small channels or shallows of shoalwater regions.

Operating Outboard Motor

WARNING! Do not over power and exceed the maximum weight of the motor! Overpowering can result in severe handling and/or stability problems with serious consequences.

Use a safety lanyard

1. Regular checks should be made on motor attachment screws. Loose screws will cause erratic boat operation and possibly the loss of your outboard motor.
2. Read the manual carefully before assembling or operating the boat.
3. On board, check that the loads are not chafing and puncturing the boat's PVC tube.

Towing your Sport Boat

The inflatable should only be towed using the D-rings near the bow on each side of the boat. Attach both D-rings to create equal tension on both sides before starting to tow. Make sure the Sport Boat is completely empty before towing process begins. *These boats are not built to tow other watercrafts, water tubes, people, floating devices, etc.*

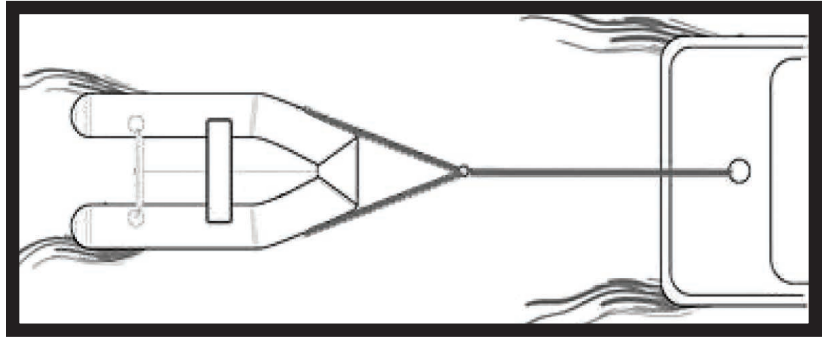

Anchoring & Mooring

The 3 bow D-rings are for anchoring and mooring.

Adding Additional Parts & Accessories

Adding Davit Points: You can add davit points to any Sport Boat. Front davit point, use front towing heavy duty D-ring. Install back davit points by drilling into the marine wood transom and installing metal davit rings. These davit U bolts can be purchased at any marine or hardware store.



Adding Dinghy Wheels: Drill holes and install into marine wood transom. Make sure to measure out where holes need to be drilled so that wheels don't hinder the PVC splash guard or motor movement.

Adding additional D-rings or fishing pole holders: You can add additional PVC D-ring patches or fishing pole holders to the dinghy by purchasing any type of PVC adhesive to install to the boat. Adhesive can be found at any marine retail store.

Air Chamber Failure

If an air chamber gets punctured during use, shift all the interior weight to the opposite side. Use your hand or any available material to prevent further air leakage and get to the nearest shore immediately.

Carbon Monoxide

The exhaust from the engine on a watercraft contains Carbon Monoxide (CO) which is a colorless, odorless and poisonous gas. Excessive exposure to CO can cause severe injury or death. Follow this advice to avoid injury.

- Never "Platform Drag" by holding onto the boarding platform or be dragged directly behind the watercraft. This is where CO will be present.
- Do not sit on the watercraft transom or boarding platform while the engine is running.
- Make sure the engine is properly tuned and running well. An improperly tuned engine produces excessive exhaust and CO.
- If you smell engine exhaust, do not stay in that position.
- Go to the United States Coast Guard's website: www.uscgboating.org for more information on how to help protect yourself and others from the dangers of CO.

Repairs and Patching

Before you begin, make sure you are working in a well-ventilated area, climate controlled to at least 70 degrees. It is advised that you wear protective gloves when working with chemicals.

Easy 5 step patch repair

- 1. FIND THE HOLE —** Inflate the tube until firm and clean with damp towel. While the tube is DRY, go over it with your hands and feel for the puncture. Often the small holes look like a scratch so check these areas first. If you find an area that you suspect is a hole, wet the area and feel for the air. Sometime you will HEAR the whistle of a small hole before you feel it. BE PATIENT. START ON THE OUTSIDE TOP AND WORK DOWN ON EACH PANEL.
- 1A. Find Quick-Fix-Patches** that were included with the product. Once you find the hole, deflate, and use these patches to repair small holes. For larger holes and more permanent repairs see below.
- 2. CIRCLE THE HOLE WITH A PEN AND THEN DEFLATE —** This will help you locate the area to patch once the tube is deflated.
- 3. CLEAN THE AREA —** Make sure the area around the hole is cleaned and dry. Then cut a patch that will fit over the hole allowing a few inches larger for gluing surface.
- 4. APPLY PVC GLUE AND PATCH —** You can find this adhesive at any West Marine or Hardware store under “inflatable PVC adhesive.” Place patch over hole and allow to dry for 15 minutes.
- 5. OUTLINE THE PATCH WITH AQUA SEAL** (sold separately) let stand for 24 hours. Aqua Seal dries very slowly, but the repair will be PERMANENT once it is sealed. Patches without Aqua Seal will work, but will not be permanent and eventually can come off. You can also PVC adhesive found at your local marine store. We suggest Clifton Urethane adhesive. You can find the glue at www.NRSWEB.com/item #1901.

Large repairs of PVC, seams, bulkheads, and transom: Contact your boat dealer or manufacture if possible. Alternative is to send your tube to a professional inflatable boat repair company for repairs. You can look online for your nearest boat repair company through Google’s search engine; enter “inflatable boat repair.” Most dealers of inflatable dinghy boats or white water rafts will have the ability to repair the tube.



Using your smart phone’s camera, TAP open the browser link that appears. Watch our video tutorial available at www.inflatableportboats.com/faq/ for helpful repair videos. Contact us if you need more help repairing your boat.

Environment Protection

Keep the oil and gas containers inside the boat, anchored/weighed or strapped down at all times while boat is in use. In case of oil or fuel leakage, reduce leak as much as possible, recuperate the waste, and head to the closest shore. Contact the local environment state board about leakage situation.

EC Declaration of Conformity

According to EC Directive "Recreational Craft" 94/25/EC, Boat XV.

We hereby declare that the boat described below; at the time it is placed on the market, meets in its design, type, and construction, the basic safety requirements of the: EC Directive for Recreational Craft.

In the event of alterations; modifications made to the boat which have not been approved by the manufacturer, Inflatable Sport Boats, and which affect the "basic safety requirements," this declaration no longer applies to that boat and is therefore null and void.

Designation of the boat: Inflatable Boat

Boat Type: Dolphin Air Floor, White Marlin Air Floor, Manta Ray, Shark, Killer Whale, Swordfish Air Floor

Main Dimensions: (8.8' x 5'), (9.8' x 5'), (8.8' x 5'), (9.8' x 5'), (10.8' x 5.3'), (10.8' x 5.3')

Design category: C (designed for voyages in coastal waters, large bays, estuaries, lakes, and rivers where conditions up to, and including, wind forces 6 and significant wave heights up to, and including 2M may be experienced.)

Certification Module: Aa

Application Directive: EC-Dir. (94/25/EC) Recreational Craft

Warranty Registration

Within 30 days of purchase date, you must log onto www.inflatableportboats.com/warranty-registration/ and complete the warranty registration form. If this is not completed within the 30 days of the purchase date, the warranty is subjected to be voided.

Workmanship Limited Warranty

On Point Products DBA: Inflatable Sport Boats warrants its Inflatable Sport Boats against defects due to substandard materials and workmanship, under conditions of normal use and service, as follows:

3 Year “No Seam Blow Out” Limited Warranty Includes:

1. The seams of each Inflatable Sport Boat are warranted for a period of three (3) years against separation or the subsequent loss of air.
2. The transom on each Boat (where installed) is warranted against separation from the hull for a period of three (3) years.
3. Accessories supplied by Inflatable Sport Boats (floorboards, oars, motor bracket, pumps, valves) and all other attachments or accessories attached by Inflatable Sport Boats or purchased from Inflatable Sport Boats for the attachment to or use on Inflatable Boats are warranted for a period of one (1) year.

The above warranty may not be transferred or assigned to subsequent owners.

Warranty Exclusions

1. This warranty does not cover any damage to the Inflatable Boat because of puncture, tearing, ripping, abrasion, ordinary wear and tear, abuse, negligence or modification to the hull.
2. This warranty shall not apply to COMMERCIAL USE or Boats subjected to negligence, accident, improper operations or trailering, improper maintenance or storage, or other than normal use or application, as described in the Inflatable Sport Boats Owner’s Manual, or to damage by circumstances beyond the control of Inflatable Sport Boats.
3. Loss or damage to the product due to abuse; towing or incorrect tethering; mishandling; alteration; accident; failure to follow maintenance or storage instructions; or any acts of God, including storm or animal damage.
4. Handles and D-rings are not covered under warranty.

Some states do not allow the limitations or exclusions of items above, so the above limitations or exclusions may not apply. This warranty gives you specific legal rights and you may also have other rights, which vary from state to state.

The obligation of Inflatable Sport Boats under these warranties is limited to replacing or compensating, within a reasonable time, such Boat or part which fall within the warranty period and to the satisfaction of Inflatable Sport Boats be determined to have been defective in material or workmanship. The decision to replace or compensate for a particular Boat or part shall be at the election of Inflatable Sport Boats. Inflatable Sport Boats may require such Boat or part to be returned to an authorized dealer or other specific location for examination.

All returns must be authorized by Inflatable Sport Boats, to be covered warranty items. If, upon examination, defects are not found to be the responsibility of Inflatable Sport Boats, customer will be notified and requested to make decision of such Boat or part. Such Boat or part will be returned freight collect.

To initiate a warranty claim, it is the responsibility of the purchaser to contact the authorized Inflatable Sport Boats dealer or Inflatable Sport Boats, 116 Talgarth Ct., Roseville, CA 95661 within a reasonable time after the discovery of the defect, providing date and proof of purchase, and details as to the nature of the defect. Taking photographs and emailing them may suffice if approved by Inflatable Sport Boats.

Manufacturer's Certificate of Origin



You will need the Manufacturer's Certificate of Origin to title and register your vessel. Please fill out with boat data provided in owner's manual and on CE plate. The H.I.N and C.I.N are the same thing and begin with AST; make sure you fill out the remaining #s and letters. DMV will also require a bill of sale, proof of purchase, or sales receipt. Fill out and cut this page out before going to DMV. For step by step instructions on how to register your Sport Boat visit our website at <https://inflatableportboats.com/registration/>

MANUFACTURER'S CERTIFICATE OF ORIGIN

1. Vessel Data:

Hull Identification Number: AST

Model Name: _____

Length: _____ Beam: _____ Draft: 6"

Place of Construction: China

Hull Material:

- Wood
- PVC
- Aluminum
- Fiberglass
- Other

2. Certification:

We at Inflatable Sport Boats Do Hereby Certify that the facts recited herein are true and that I have personal knowledge of these facts because I:

- A. Personally performed the construction
- B. Supervised the construction at and on behalf of

Inflatable Sport Boats

(Name of Company)

Signature: Lin CB

Date: _____



Available Accessories

Aluminum Bench Seat

The slide on bench seats can be adjusted one foot forward or backwards.



Seat Cushion and Bag

A comfortable seat cushion with a detachable bag under the seat.



Aluminum Carry Storage Floor Bag

Bag for dinghy aluminum and/or marine wood flooring pieces.



Air Floor Insert

Air floor insert can be substituted in for any aluminum floor boats.

- Drop stitch air floor
- UV and puncture resistant
- Inflate to 8 PSI
- Extremely stiff and ridged



EVA Teak Wood Foam Decking

The padded EVA foam teak wood flooring easily peels and sticks on your aluminum or air floor inserts.



Aluminum Floor Insert

Aluminum flooring inserts can be substituted in for any air floor boat.

- Aluminum pieces
- Bow floor board is marine plywood



Dinghy Wheels

Install into the wood transom. Foldable and removeable wheels.



Bimini Top

Canopy for your boat to provide some shade.



Magic Air Blower

3 different model options.

- Model 1: 110 volt AC wall plugin
- Model 2: 12 volt cigarette lighter outlet
- Model 3: 12 volt battery clamps



ISUP Kayak Sea

Attachable ISUP kayak seat that clips onto the pre-installed d-rings.



Inflatable Pillow

Pillow for Yacht Dock. Inflated dimensions: 6' long x 2' wide x 2' thick.



ISUP Auto Set Power Pump

PSI auto set inflator for your Drop Stitch inflatable platforms and ISUPs. Set it to 15PSI and walk away. Comes with 12 volt cigarette and battery clamp hookups.



Using your smart phone's camera, TAP open the browser link that appears. This will take you to the accessories webpage.



Inflatable Sport Boats by On Point Products Inc.
116 Talgarth Ct., Roseville, CA 95661
Sacramento, CA 95834

